

**\*\* PROPRIETARY AND CONFIDENTIAL \*\***  
Copyright © 2015 Sun West Engineering, Inc.

THIS PROPOSAL CONTAINS TRADE SECRETS AND OTHER PROPRIETARY AND CONFIDENTIAL INFORMATION OF SUN WEST ENGINEERING, INC.

THIS DOCUMENT AND ITS CONTENTS, INCLUDING WITHOUT LIMITATION THE DRAWINGS AND OTHER INFORMATION HEREIN, ARE THE SOLE AND EXCLUSIVE PROPERTY OF SUN WEST ENGINEERING, INC.

ANY DUPLICATION, DISCLOSURE, OR USE OF ANY PORTION OF THIS DOCUMENT REQUIRES THE PRIOR WRITTEN CONSENT OF SUN WEST ENGINEERING, INC.



# SPRINTER VAN

## VAN SPECIFICATIONS

- Mercedes-Benz 3500 Sprinter Cargo Van—11,030-lb GVW
- Standard 2-Stage Turbo 4-Cyl Diesel Engine with 7-Spd Transmission
- 3-Year / 36,000-Mile Warranty on Van
- 5-Year / 100,000-Mile Warranty on Diesel Engine
- Choice of 144" or 170" Wheelbase with Extended Length
- Individual Cloth Covered Driver and Passenger Seats
- Premium Interior Trim Package Includes; Cruise Control, Tilt Steering, Air Conditioning AM/FM/CD Satellite-Ready Stereo and Back-up Camera

## VAN CONFIGURATION & OPTIONS

- Mast:**
- 42' Pneumatic Heavy Duty Locking, with Rotating Base, 150-lb. Capacity
  - Complete 2-Level, 4-Way Guy Kit & Protective Weather Cover Included
- Generator:**
- 10 Kw Cummins Onan Diesel (Auto Start)
  - 1Ø 120 Volt 83.3 Amps
  - 1Ø 240 Volt 41.7 Amps
  - Automatic Transfer Switch
  - 100 AMP 6-Position 1Ø 3-Wire Dist. Panel
  - Remote Shore Plug Connection
  - 20' 240v Twist-lock Power Cable
- Van Upfit:**
- 19"/23" Racks For Customer Installed Equipment
  - 1" Foam Insulated Walls, Ceiling and Door Areas
  - Walls, Ceiling & Floor Areas Covered With ½" Plywood and Electrostatic Discharge Resistant Fabric
  - Ranger® Aluminum Front Partition With Locking Sliding Door To Rear Of Vehicle
  - 15,000 BTU HVAC Unit with Heat Strip
  - Slip Resistant Loncoin Vinyl Flooring
  - Ceiling Mounted LED Work Lights per Design
  - Purpose Built Roof-Mounted Crow's Nest Work Area with Weatherproof R/F Entry Port
  - Storage Container with Tool Box and Basic Tool Set
- Options/Add-ons:**
- Fully Automatic Hydraulic Vehicle Leveling System:
    - 4,000 lbs. lifting capacity per jack on the front
    - 6,000 lbs. lifting capacity per jack on the rear
  - 30' 150-lb. Capacity Mast in-lieu of 42' Mast
  - 60' 200-lb. Capacity Mast in-lieu of 42' Mast
  - Work Station with Overhead Storage Compartment
  - 3-Sector Antenna Mounting System
  - Pan & Tilt Microwave Mount with Controller
  - Mid-Level Microwave Mount
  - Emergency Lighting Package, Flashers and Beacon



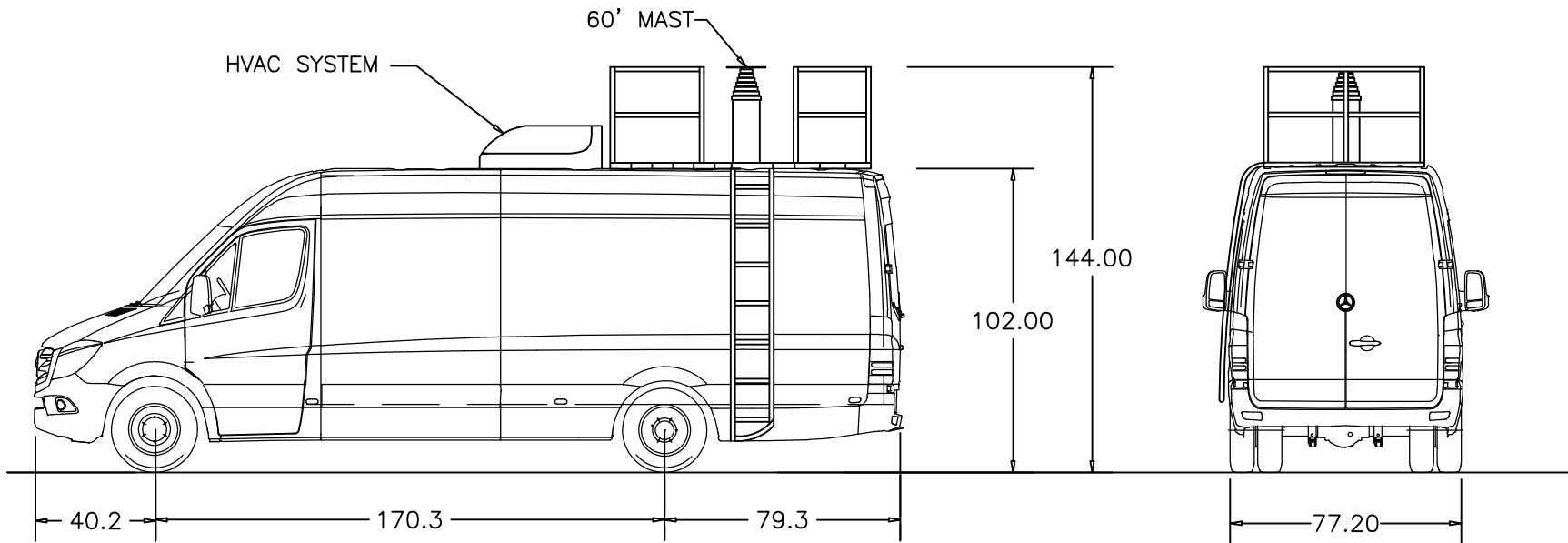
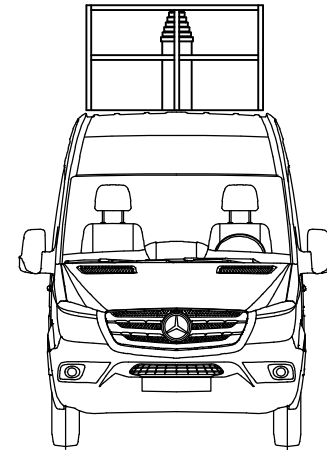
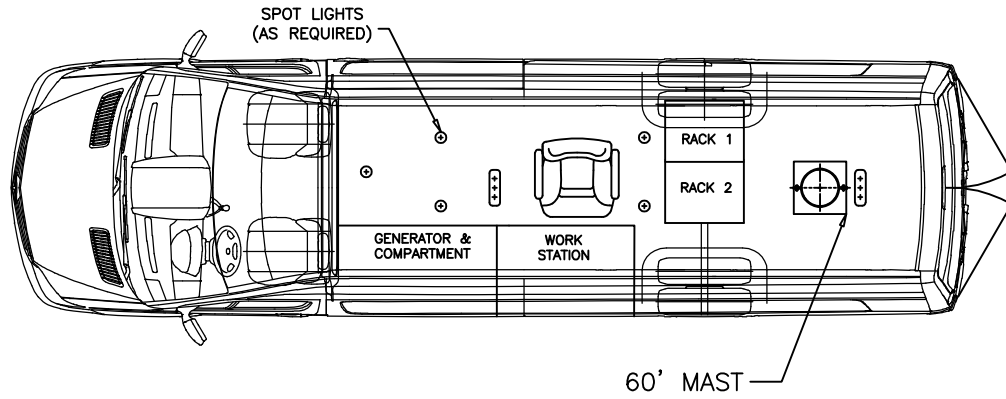

ACCESS LADDER

**PROPRIETARY  
PROPOSAL**

**\*\* PROPRIETARY AND CONFIDENTIAL \*\***

Copyright © 2014 Sun West Engineering, Inc.  
 THIS PROPOSAL CONTAINS TRADE SECRETS AND OTHER PROPRIETARY AND CONFIDENTIAL INFORMATION OF SUN WEST ENGINEERING, INC. THIS DOCUMENTS AND IT'S CONTENTS, INCLUDING WITHOUT LIMITATION THE DRAWINGS AND OTHER INFORMATION HEREIN, ARE THE SOLE AND EXCLUSIVE PROPERTY OF SUN WEST ENGINEERING, INC.  
 ANY DUPLICATION, DISCLOSURE, OR USE OF ANY PORTION OF THIS DOCUMENT REQUIRES THE PRIOR WRITTEN CONSENT OF SUN WEST ENGINEERING, INC

	<b>SUN WEST ENGINEERING, INC.</b> 3802 S. 38th ST., PHOENIX, AZ 85040 (602) 275-0862	
	TITLE: CARGO VAN - SPRINTER 170" WB	
CUSTOMER:		
PLOTTED SCALE: .XXXX=1	SHEET: 1 of 1	
DRAWN BY: <i>HJM</i>	DATE DRAWN: 7-29-14	
REVISED: 12-15-14	DWG. No. SW-4863	